

EARTHQUAKES AND TSUNAMIS

HIGH SCHOOL TEACHER'S GUIDEBOOK

SERVICIO HIDROGRAFICO Y OCEANOGRAFICO DE LA ARMADA DE CHILE
INTERGOVERNMENTAL OCEANOGRAPHIC COMMISSION
INTERNATIONAL TSUNAMI INFORMATION CENTER

EARTHQUAKES AND TSUNAMIS

HIGH SCHOOL TEXTBOOK

Teacher's Guide

CHAPTER 1

"OUTSIDE AND INSIDE THE EARTH"

1.1.- CHARACTERISTICS OF THE EARTH

A.-SHAPE AND DIMENSIONS OF THE EARTH

SPECIFIC OBJECTIVE: Describe and identify the shape and dimensions of the earth.

SUGGESTED ACTIVITIES:

Compare characteristics and general conditions of planet earth with other planets of the solar system. - Compare different terrestrial measurements (radius, diameter, perimeter), both radial and polar. Calculate the percentage difference. Make a drawing of the earth or something of similar shape and apply the percentage difference.

B.- DISTRIBUTION OF OCEANS AND CONTINENTS.

SPECIFIC OBJECTIVE: Describe and locate the oceans and continents. Describe the general topographic features of the sea bottom.

SUGGESTED ACTIVITIES:

- Compare the measurements and characteristics of the different oceans and compare them with the continents' measurements.
- Locate different trenches and ridges of the oceans, especially those in the Pacific Ocean.

1.2.- INTERNAL STRUCTURE OF THE EARTH**A.-SEISMIC WAVES**

SPECIFIC OBJECTIVE: Describe seismic waves generation and propagation, and show classification.

SUGGESTED ACTIVITIES:

- Find out and write an article with the style of a magazine report about Jules Verne and his work journey to the center of the earth".
- Visit an oceanographic, geographic or seismological center where you can see a seismograph in operation.
- Analyze, make a graph, and compare the different types of seismic waves.
- Invent some kind of representation of seismic waves, utilizing springs, wooden cubes, dominoes, etc. giving them some kind of force to simulate their action.

B.- LAYERS OF THE EARTH

SPECIFIC OBJECTIVE: List, describe and compare the earth's layers.

SUGGESTED ACTIVITIES:

- Compare both types of classification of the layers of the earth, making a comparative drawing or table.
- Work with different density materials (mixtures of soil and water, clay, brick pieces) to show how the earth's layers behave according to their viscosity.

SUGGESTED METHODOLOGY

- Create work groups to develop different activities. Use questions/problems from the textbook.

- Nurture in your students a creative and critical spirit when dealing with the different subjects.
- Distribute the subjects among the students, to be treated in groups or individually, and present the results in front of the class.
- Analyze and discuss the reports provided at the end of each chapter. Obtain and discuss personal accounts of personal or general experiences from other information sources.

CORRECTION GUIDELINES FOR CHAPTER TEST

A.- VOCABULARY: B.- MULTIPLE CHOICE

- | | |
|--------|-------|
| 1.- C | 1.- B |
| 2.- D | 2.- B |
| 3.- F | 3.- B |
| 4.- B | 4.- B |
| 5.- A | 5.- D |
| 6.- I | 6.- C |
| 7.- E | 7.- A |
| 8.- J | 8.- C |
| 9.- H | |
| 10.- G | |

SUPPORT MATERIAL FOR TRANSPARENCIES

Use the attached diagrams to make your transparencies. You can transfer drawings by tracing them with transparency pencils or by photocopying them. You can then color the transparencies if you wish.

CHAPTER 2

THE EARTH'S CRUST ON THE MOVE

2.1.- THE JIGSAW PUZZLE OF THE CONTINENTS.

SPECIFIC OBJECTIVE: Explain the meaning of continental drift.

SUGGESTED ACTIVITIES:

- Cut out the map of the world and assemble the jigsaw puzzle of the continents, bringing together the pieces that fit. Compare this continent" with different representations of Pangaea.
- Use library sources to create a biographical sketch of Alfred Wegener.

2.2.- DISCOVERIES IN THE OCEAN

SPECIFIC OBJECTIVE: Identify the evidence for sea floor spreading.

SUGGESTED ACTIVITIES:

- On a map, locate oceanic trenches and ridges (activity - chapter 1), and include tectonic plates, show the direction they move and identify them by their location and name.
- Make a drawing (a profile) showing how close the continental ridges are to the oceanic trenches.

2.3.- PLATE TECTONICS, A NEW THEORY

SPECIFIC OBJECTIVE: Compare three types of plate boundaries.

SUGGESTED ACTIVITIES:

- Cut out a map by the plate boundaries, noting these could contain continental and oceanic crust. Displace the plates in the direction they move. Note what this means for continental masses.
- Locate on a plate tectonics map the different types of plate boundaries.

2.4.- FORCES STRONG ENOUGH TO MOVE PLATES

SPECIFIC OBJECTIVE: Describe two forces that could cause the movement of the plates.

SUGGESTED ACTIVITIES:

- Boil water in a glass pan under low heat, and slowly add coloring in order to see the convection currents. Compare this phenomenon with that described in the textbook in reference to tectonic plates.
- Analyze the report "To lubricate the earth". Comment on it as a group. Compare it with the report in Chapter 1 "Animals predict earthquakes". Have the group compile a list of ideas.
- Compare the different forces described in the textbook: convection, plumes in the mantle, hot spots. Establish relationships and differences between them.

GENERAL METHODOLOGICAL SUGGESTION

- Use the questions/problems section to encourage participation and creativeness.

CORRECTION GUIDELINES FOR CHAPTER TEST

A.- VOCABULARY: B.- MULTIPLE CHOICE

- | | |
|-------|-------|
| 1.- E | 1.- B |
| 2.- D | 2.- B |
| 3.- G | 3.- A |
| 4.- I | 4.- B |
| 5.- A | 5.- A |
| 6.- B | 6.- B |
| 7.- C | 7.- D |
| 8.- F | 8.- A |
| 9.- B | 9.- B |

CHAPTER 3

SEISMICITY OF THE EARTH AND VOLCANOES"

3.1. EARTHQUAKES

SPECIFIC OBJECTIVES:

- Explain existing relationships between faults, earthquakes and plate boundaries, showing the geographical distribution of the seismic events.
- Explain how scientists use seismic waves to locate an earthquake's epicenter.

SUGGESTED ACTIVITIES.

- Locate seismic zones and active volcanoes on a map of the country and see the relationships they have with plates and trenches.
- Locate on a world map the aseismic continental and oceanic zones.
- Develop the activity "Locating an earthquake" It can be worked as group activity changing the scale from centimeters to decimeters and using a big sheet of paper.

3.2. MAGMA AND LAVA

SPECIFIC OBJECTIVES:

- Contrast the formation of intrusive and extrusive rocks.
- Describe four types of volcanic cones.

SUGGESTED ACTIVITIES:

- Get different types of volcanic rocks and compare them in weight, texture, color, and shape. Make a collection of rock samples.
- Identify and draw the volcanic cone types that are found in your country. Analyze their origin.
- Develop the activity "Earthquakes and volcanoes" in small working groups.

CORRECTION GUIDELINES FOR CHAPTER TEST

A.- VOCABULARY B.- MULTIPLE CHOICE

- 1.- C
- 2.- A
- 3.- E
- 4.- H
- 5.- D
- 6.- I
- 7.- F
- 8.- G
- 9.- B

- 1.- C
- 2.- A
- 3.- B
- 4.- C
- 5.- A
- 6.- B

CHAPTER 4**"TSUNAMIS"****4.1. WHAT IS A TSUNAMI?****SPECIFIC OBJECTIVE:**

- Describe the tsunami waves.

SUGGESTED ACTIVITIES:

- Get a documented report or video about the phenomenon tsunami, and analyze the concepts given there with the acquired knowledge through the textbook.
- Throw a stone into a bucket of water and watch the generation and rebound of waves. Associate this effect with the phenomenon tsunami.

4.2. WHAT CAUSES A TSUNAMI?

SPECIFIC OBJECTIVES:

- Explain the origin of the phenomenon's name.
- Define generation mechanisms.

SUGGESTED ACTIVITIES:

- Make a list of the different terms or expressions used to define the phenomenon tsunami.
- Relate the occurrence of an earthquake with tsunami generation. Provide an example.
- Make a list of known tsunamis specifying the cause of each.

4.3. GENERATION OF TSUNAMIS

SPECIFIC OBJECTIVE:

- Define tsunami transformations from their origin zone.

SUGGESTED ACTIVITIES:

- Annotate the differences between a distant and a local tsunami.
- Relate tsunami occurrence with magnitude value and location of an earthquake.

4.4. TSUNAMI PROPAGATION

SPECIFIC OBJECTIVE:

- Describe tsunami propagation and wave transformations.

SUGGESTED ACTIVITIES:

- Determine how long it takes for a tsunami generated in Japan, traveling at different speeds (600, 700, or 850 km/hr) to cross the Pacific Ocean and reach Chile.
- Compare tsunami wave diffraction and refraction, from the acoustic and optical point of view.

4.5. COASTAL EFFECTS

SPECIFIC OBJECTIVE:

- Describe tsunami coastal effects.

SUGGESTED ACTIVITIES:

- Using different materials (sand, clay, stones, etc.) simulate coastal relief in a large tray with water. Produce different wave effects and watch their behavior. Record and compare observations.
- If possible, visit a beach and observe the effects of waves.

4.6. THE TSUNAMI WARNING SYSTEM

SPECIFIC OBJECTIVE:

- Describe the Tsunami Warning System.

SUGGESTED ACTIVITIES:

- List participating countries in the Tsunami Warning System of the Pacific.
- Describe the operation of the Tsunami Warning System.

CORRECTION GUIDELINES FOR CHAPTER TEST

A.- VOCABULARY B.- MULTIPLE CHOICE

- | | | |
|-------|-------|-------|
| 1.- C | 1.- D | 5.- C |
| 2.- D | 2.- B | 6.- A |
| 3.- E | 3.- D | 7.- D |
| 4.- A | 4.- B | 8.- B |
| 5.- B | | |

CHAPTER 5

"SEISMICITY OF THE COUNTRY"

5.1. GENERAL CHARACTERISTICS OF THE SEISMICITY

SPECIFIC OBJECTIVE:

- Describe the characteristics of earthquake occurrences in your country.

SUGGESTED ACTIVITY:

- Locate on a map of your country the tectonic plates affecting the country, as well as the trenches, faults and types of plate boundaries.

5.2. SEISMIC REGIONALIZATION

SPECIFIC OBJECTIVES:

- Determine the ways in which seismic activity occurs in different parts of your country.
- Describe historical seismic occurrences in your country.

SUGGESTED ACTIVITIES:

- Show in regional maps the following features:
 - a) Seismic activity during 18th, 19th and 20th centuries.
 - b) Seismic activity of magnitude greater than 7.5.
 - c) Seismic activity producing big tsunamis.

CHAPTER 6

"EARTHQUAKE AND TSUNAMI PROTECTION MEASURES"

6.1. WHAT TO DO BEFORE AN EARTHQUAKE.

SPECIFIC OBJECTIVE:

- Describe how to be prepared for the occurrence of a big earthquake.

SUGGESTED ACTIVITIES:

- "Brainstorm" for ideas: encourage students to develop an action plan prior to the occurrence of an earthquake. In groups, approach this phenomenon at different locations (home, school, movies, street, etc.).
- Prepare a family strategy for an earthquake and/or tsunami.
- Make a list of basic first aid elements.
- Recognize dangerous places and situations in case of an earthquake.
- Form collaborative groups for evacuation of small children.

6.2. WHAT TO DO DURING THE SHAKING - DON'T PANIC.

SPECIFIC OBJECTIVE:

- Describe actions to take during a big earthquake to be safe from its effects.

SUGGESTED ACTIVITIES:

- "Brainstorm" for ideas: develop specific strategies related to the family and the class.

6.3. WHAT TO DO AFTER THE SHAKING STOPS - STAY CALM.

SPECIFIC OBJECTIVE:

- Describe actions to do after the occurrence of a big earthquake.

SUGGESTED ACTIVITIES:

- Practice evacuation procedures.
- Evaluate and correct detected deficiencies.

6.4. WHAT TO DO IN CASE OF A TSUNAMI.**SPECIFIC OBJECTIVE:**

- Describe actions to take in case of a tsunami.

SUGGESTED ACTIVITIES:

- "Brainstorm" for ideas: encourage students to make an action plan prior the occurrence of a tsunami. In groups, approach this phenomenon at different locations (home, school, movies, street, etc.).
- Prepare a family strategy for a tsunami occurrence.
- Make a list of basic first aid elements.
- Recognize dangerous places and situations in case of a tsunami.
- Form collaborative groups for evacuation of small children.

CORRECTION GUIDELINES FOR CHAPTER TEST**A.- MULTIPLE CHOICE**

- 1.- D
- 2.- B
- 3.- C
- 4.- C
- 5.- B

WORLD MAP WITH EPICENTERS

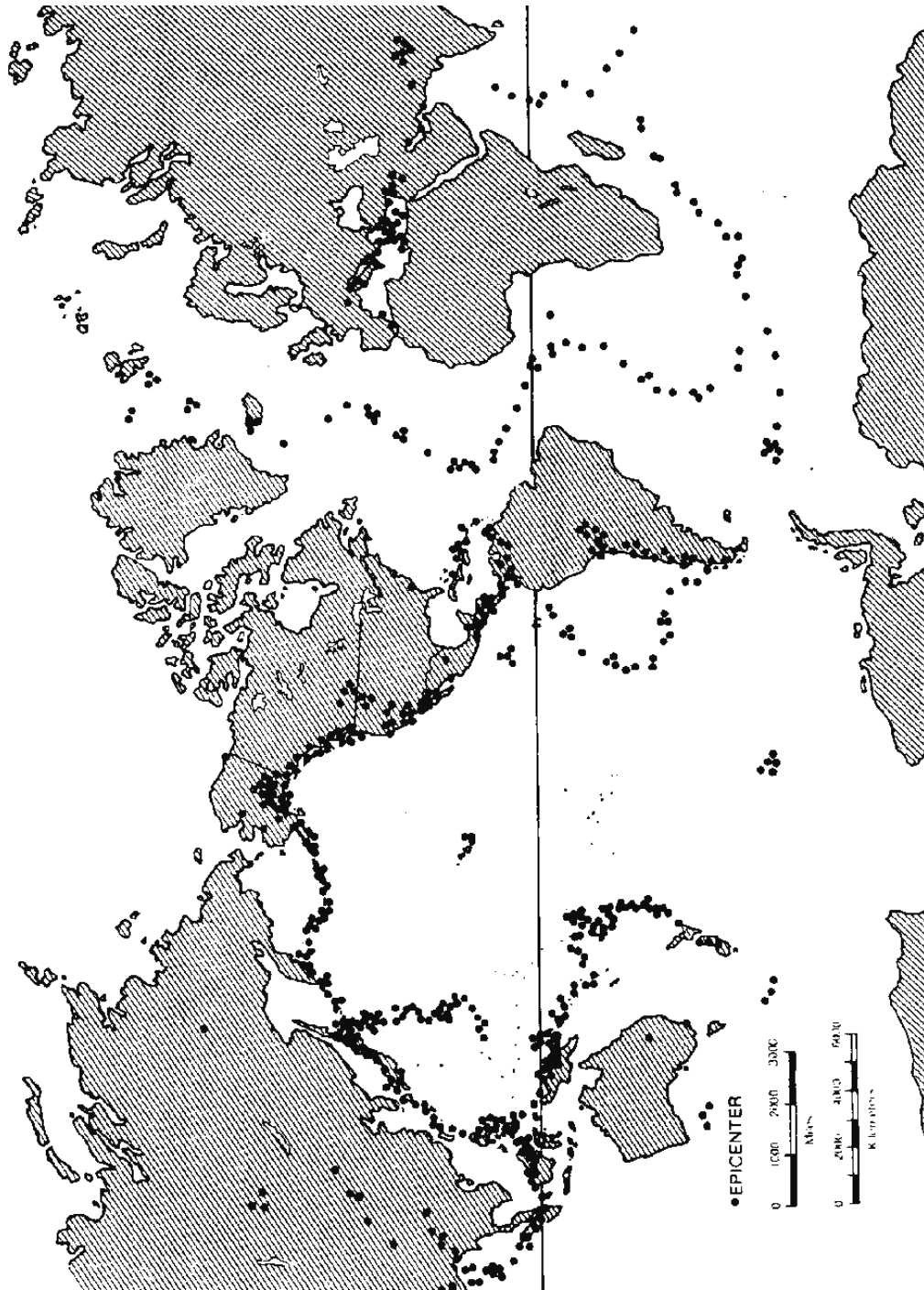

EARTH PLATES

Name: _____

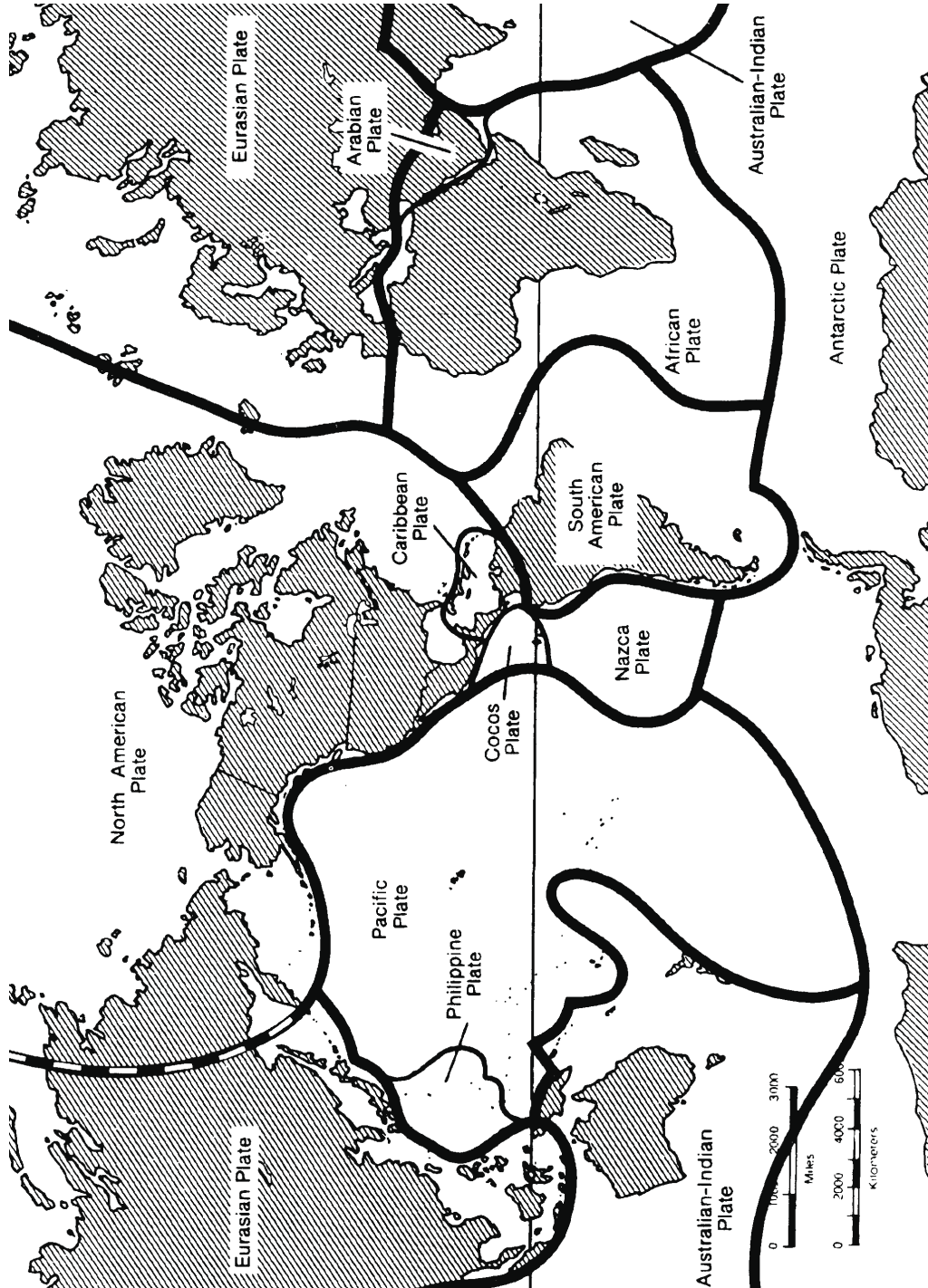

A PIECE OF THE EARTH

Name: _____

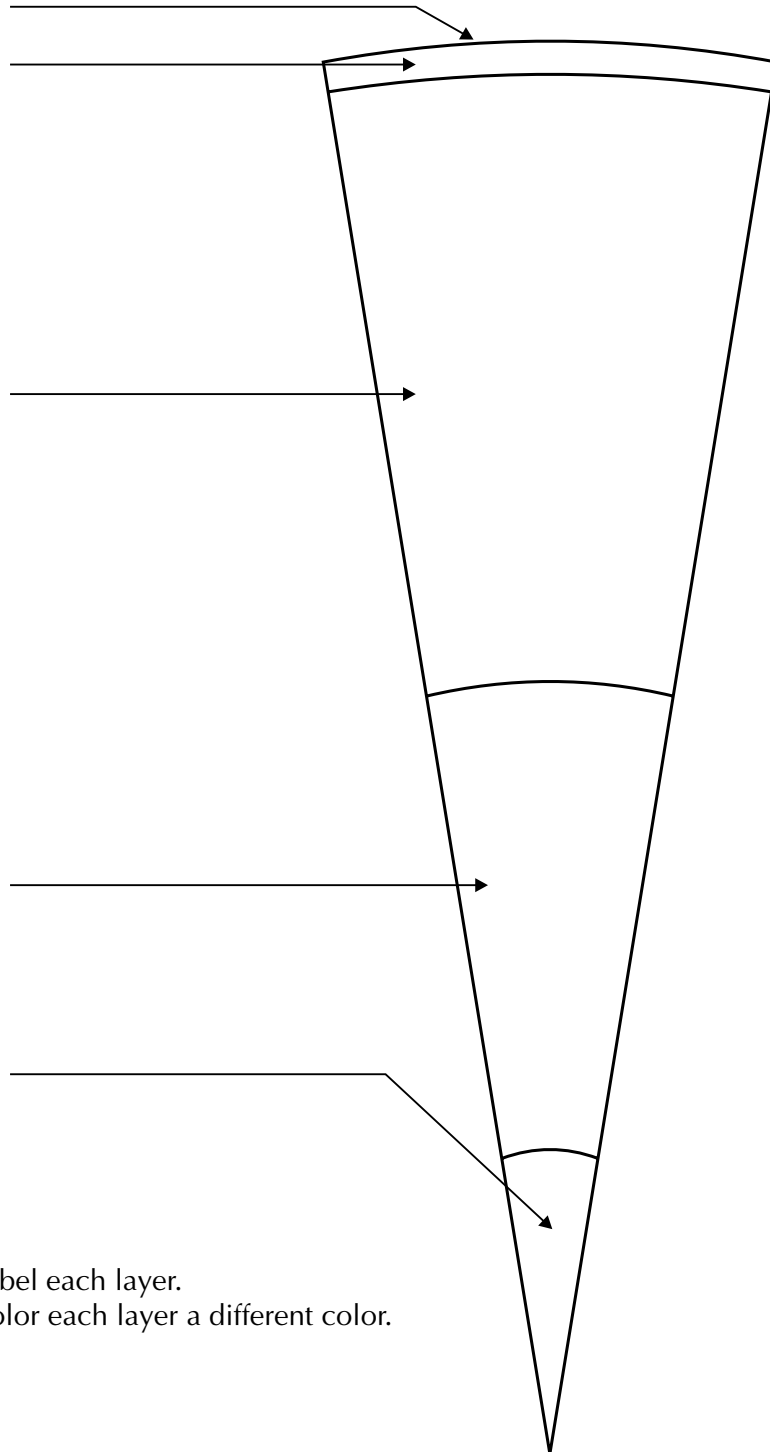

- 1.- Label each layer.
- 2.- Color each layer a different color.

ELASTIC REBOUND

STICK CHANGES

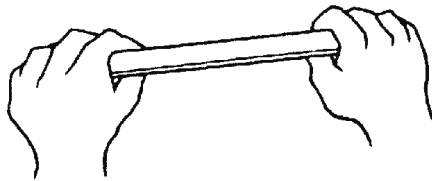

Original position with no strain on sticks and rocks.

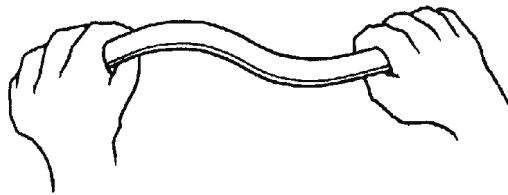

Buildup of potential energy in bent stick and deformed rocks.

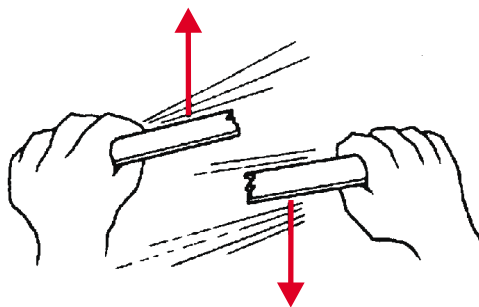

Breaking stick and rocks produces break (fault) and energy release or earthquake.

ROCK CHANGES

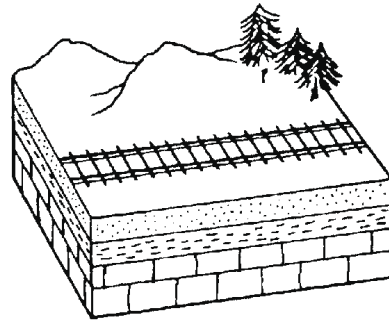

Pressure direction

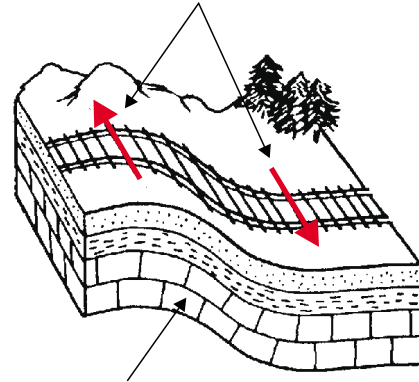

Deformed rocks

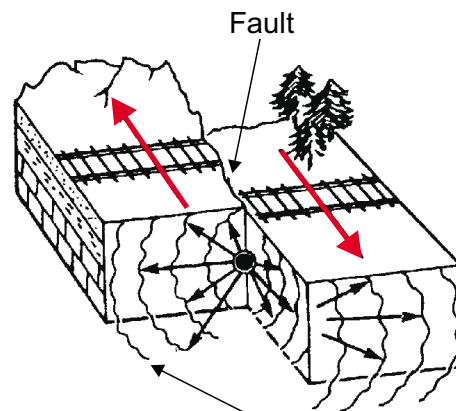

Earthquakes waves

LAYERS OF THE EARTH

Name: _____

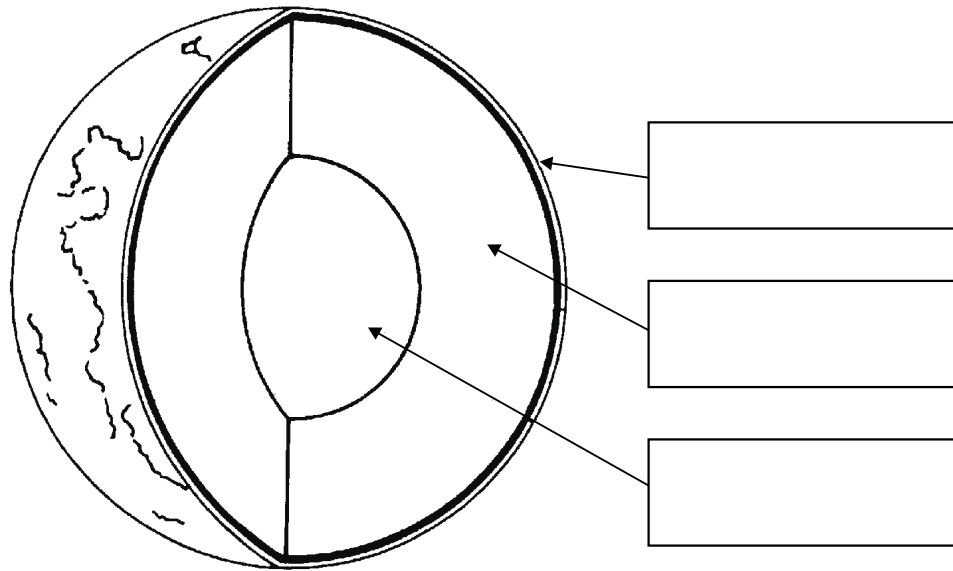

1.- Color the layers of the earth.

2.- Cut out the words and paste them in the correct boxes.

Crust

Mantle

Core

PLATE BOUNDARIES MAP

Name: _____

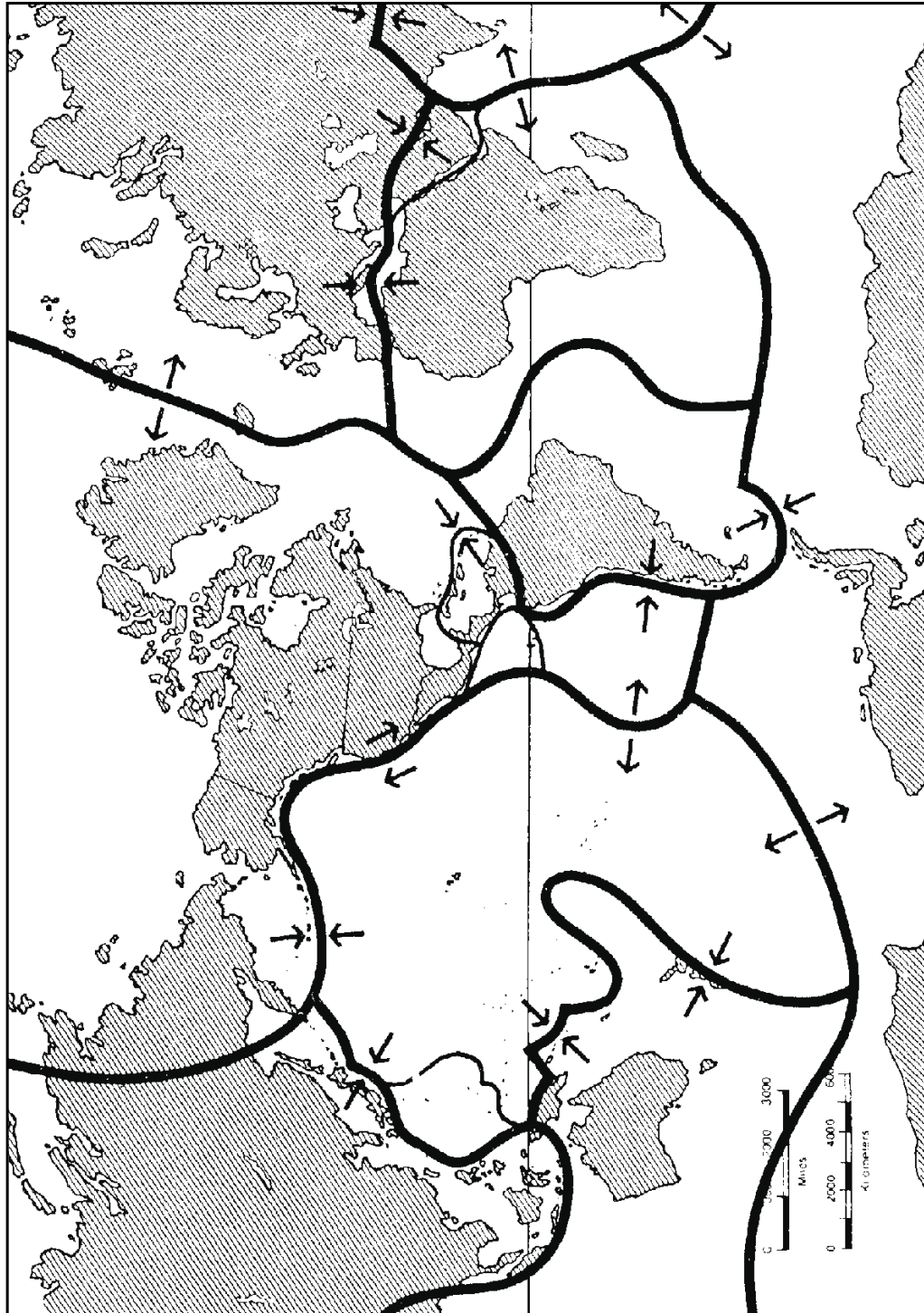

CONVECTION CURRENTS AND PLATE CROSS SECTION

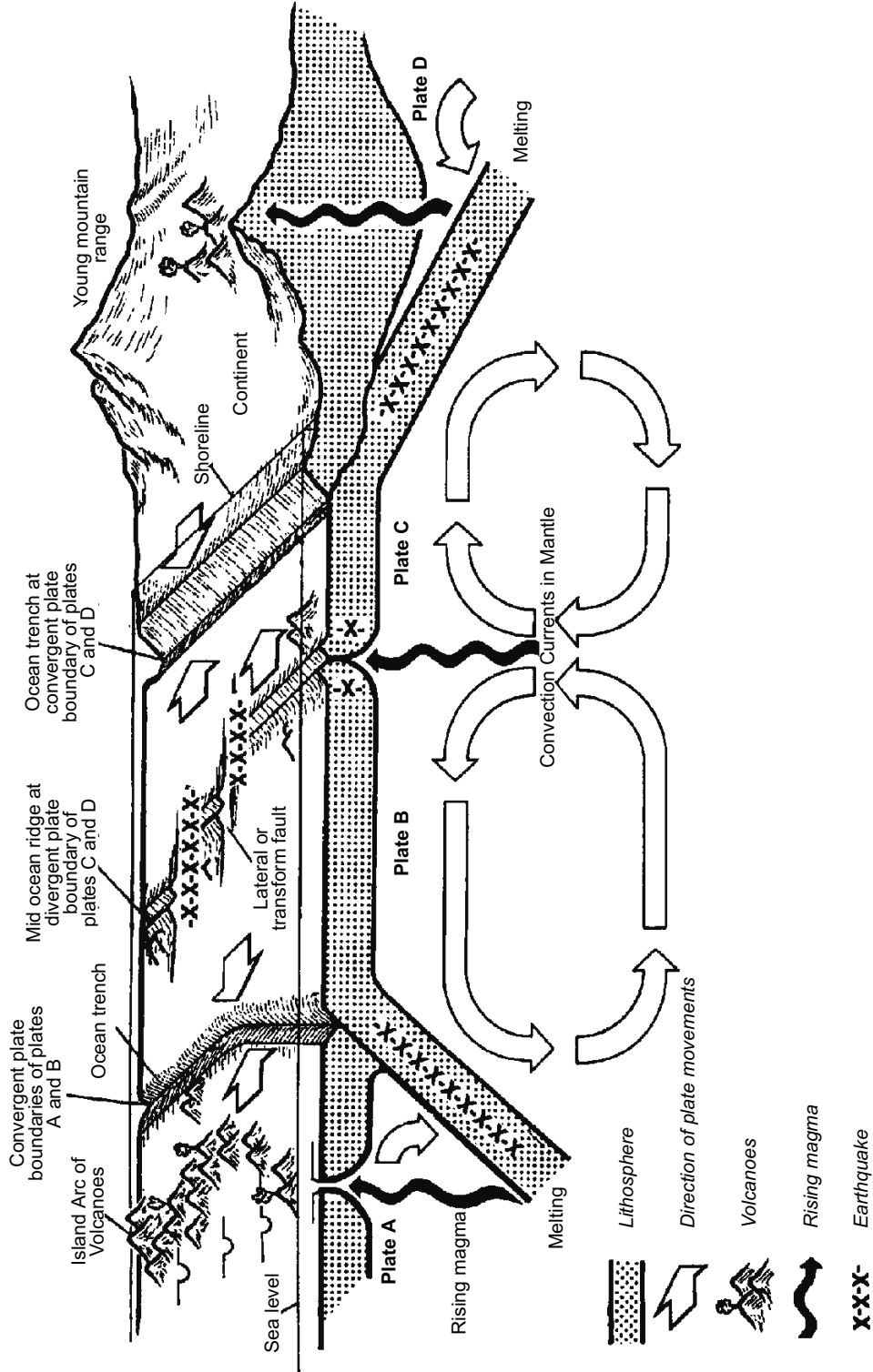

SEISMOGRAPHS

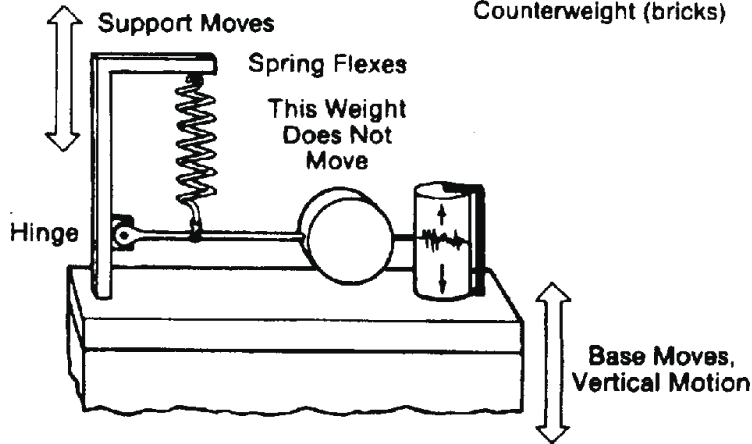
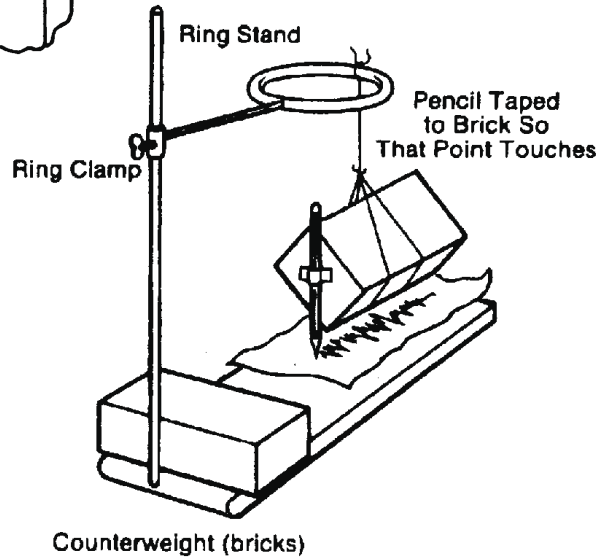
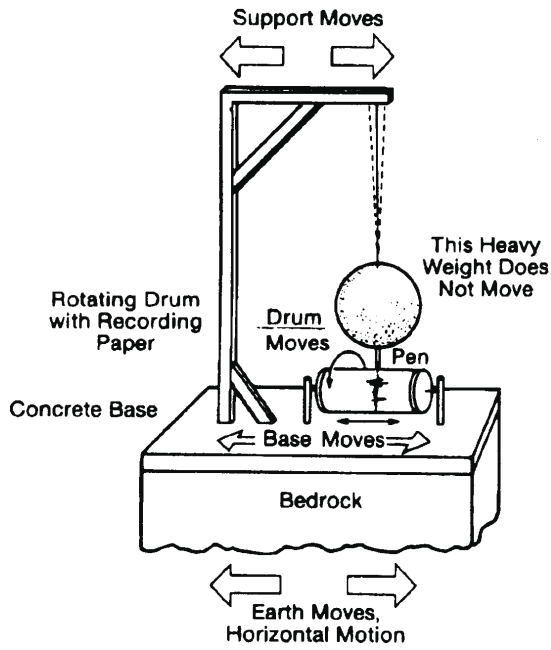

P-WAVE MOTION AND S-WAVE MOTION

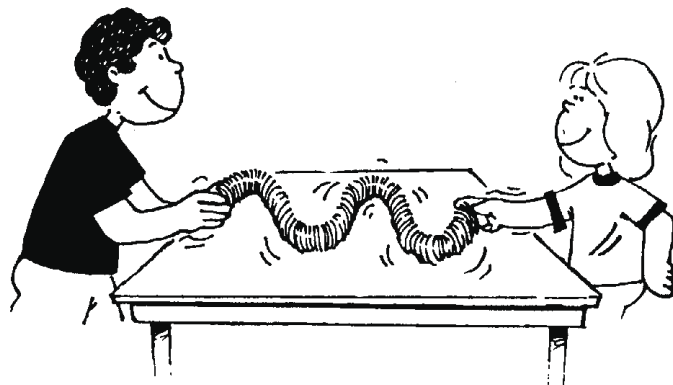
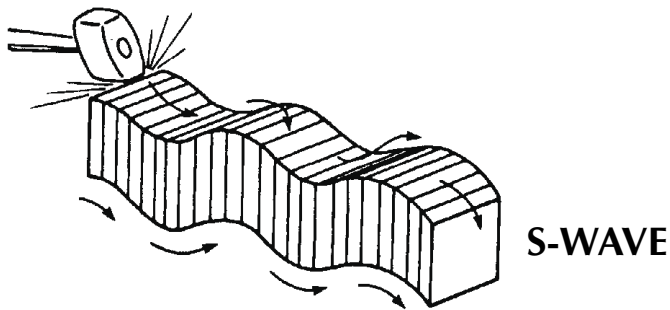
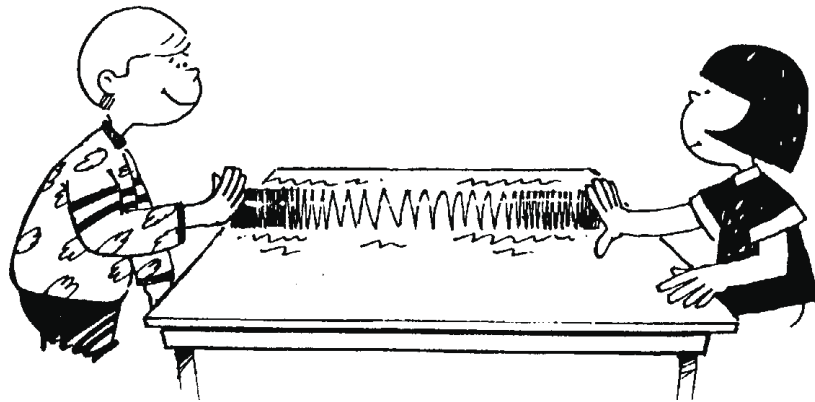
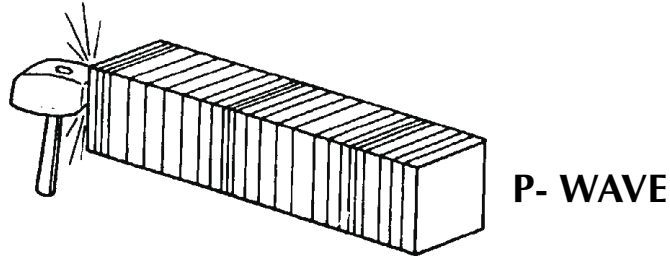

NEIGHBORHOOD



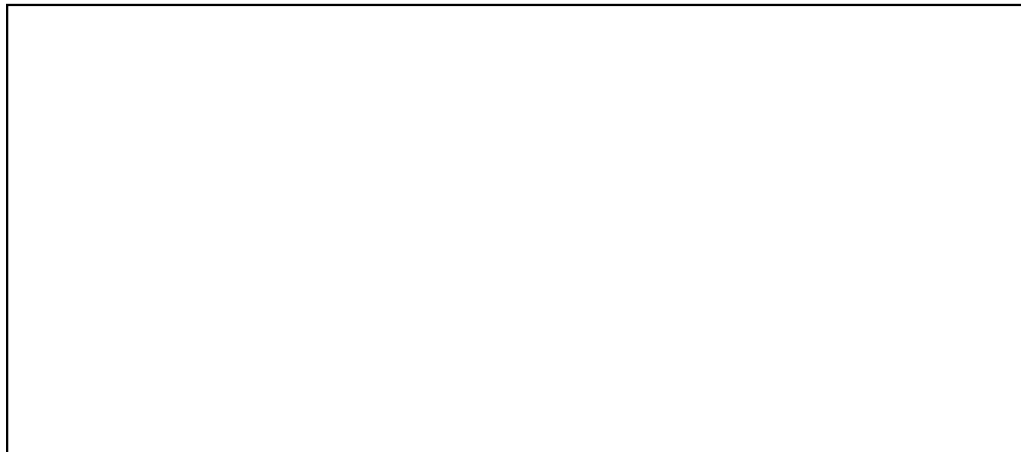
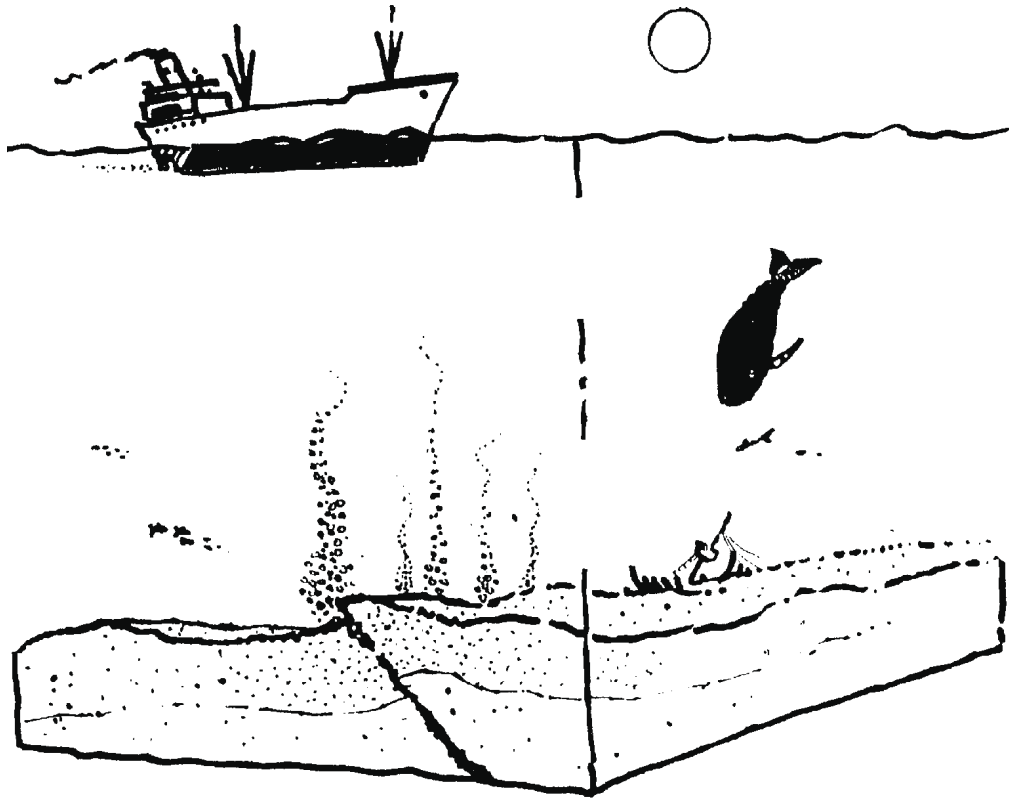

TSUNAMI

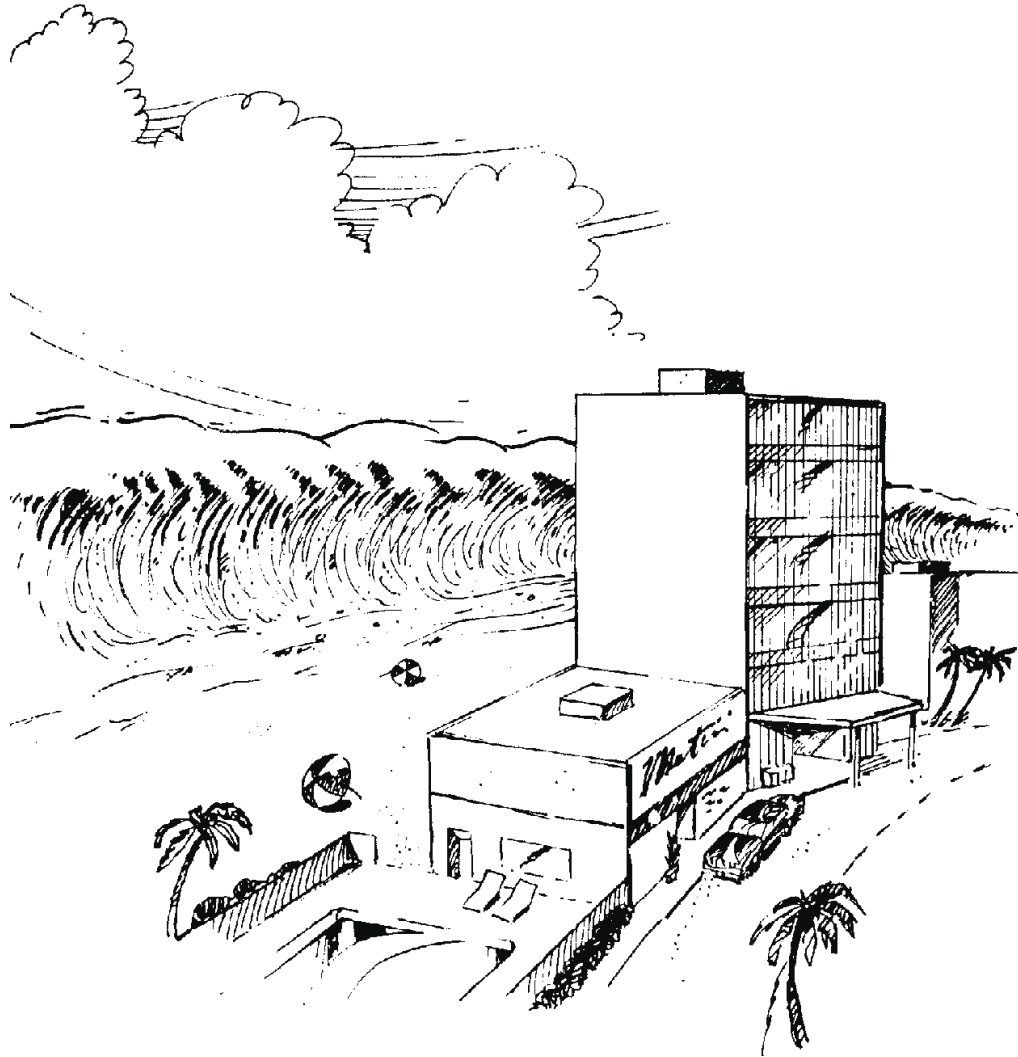

DOWNTOWN

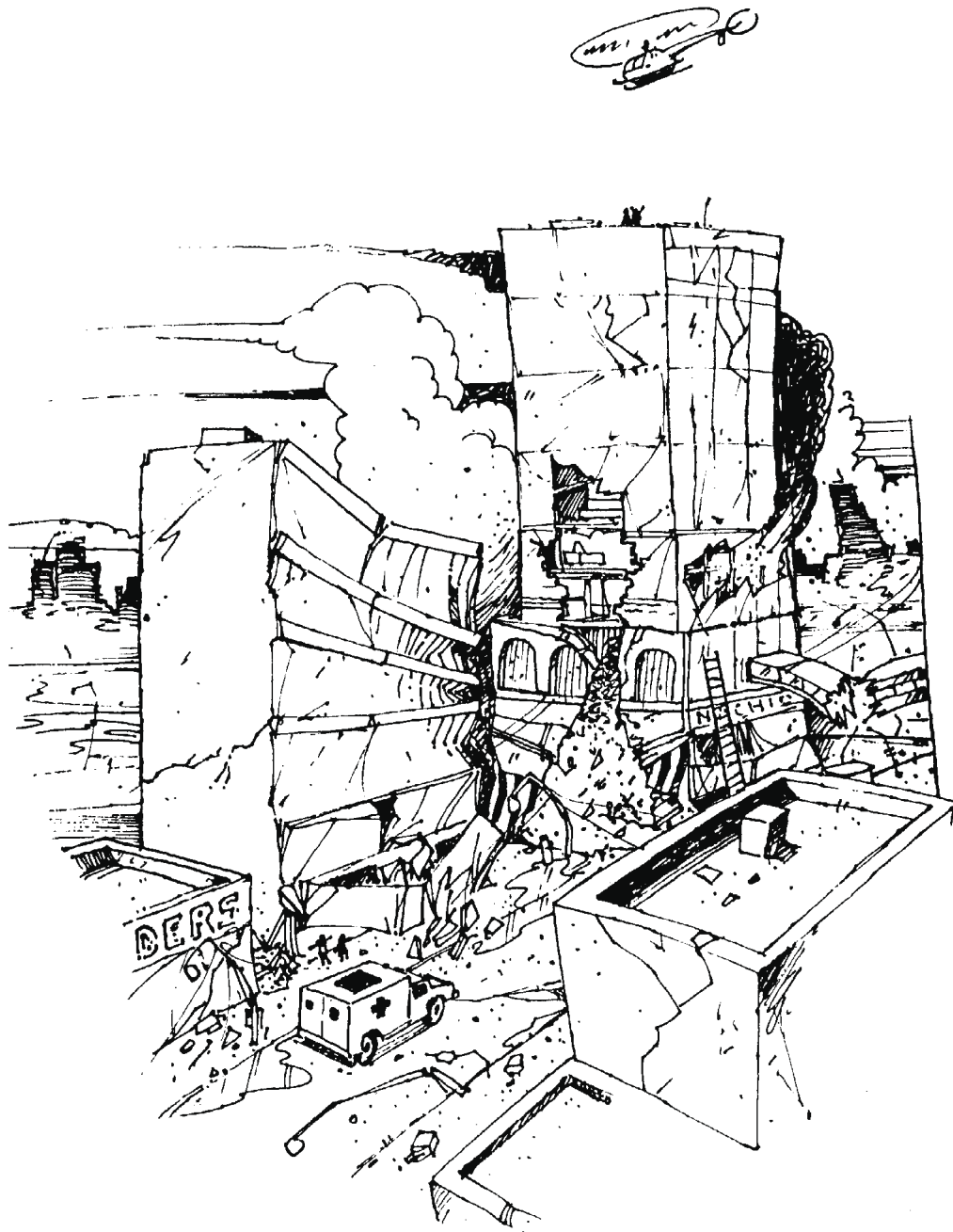

HOME HAZARD HUNT WORKSHEET

Name: _____

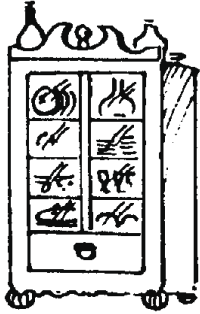

1. China cabinet

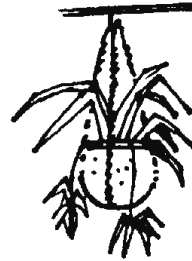

5. Hanging plant



2. Tall knickknack shelves



6. Mirror on wall



3. Bookshelves



7. Heavy objects on wall shelves

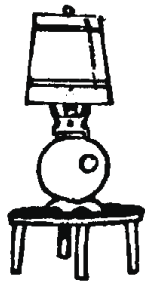

4. Tall, heavy table lamp

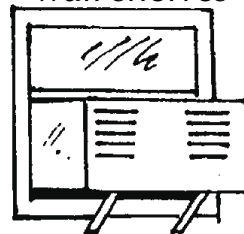

8. Window air conditioner

Name: _____



9. Hanging lamp or chandelier

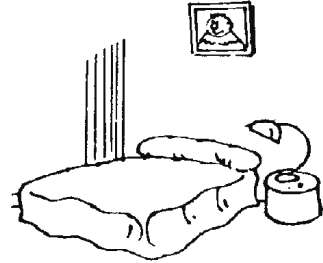

13. Heavy picture above bed



10. Unsecured TV or cart with wheels

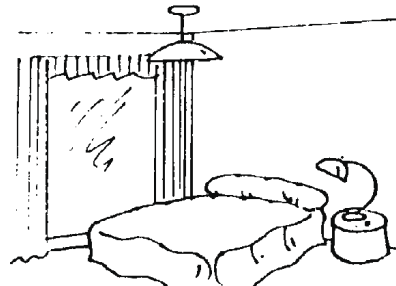

14. Hanging light above bed

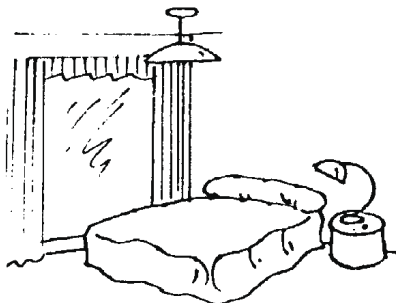

11. Bed by big windows

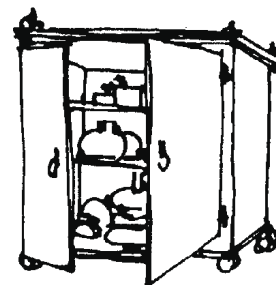

15. Cabinet doors not fastened

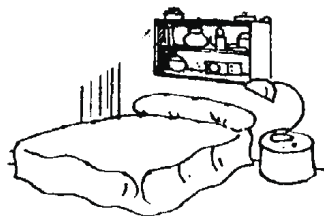

12. Heavy objects on shelves above bed

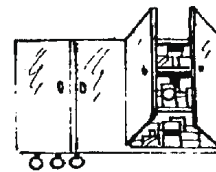

16. Medicine cabinet doors not fastened

Name: _____

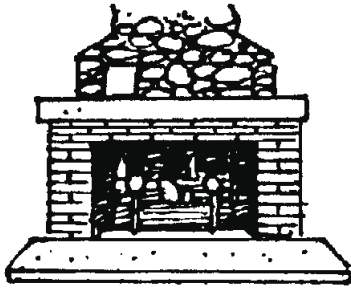

17. Fireplace bricks

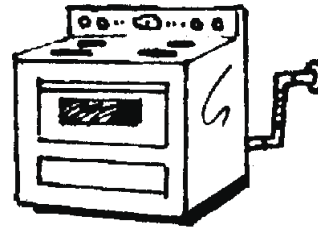

20. Gas stove with rigid feed line

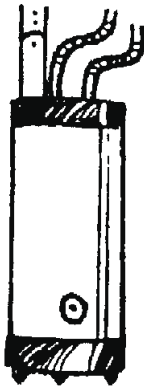

18. Unattached water heater

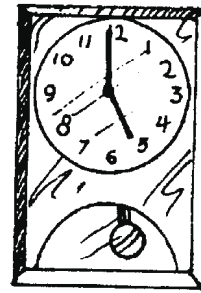

21. Heavy wall clock

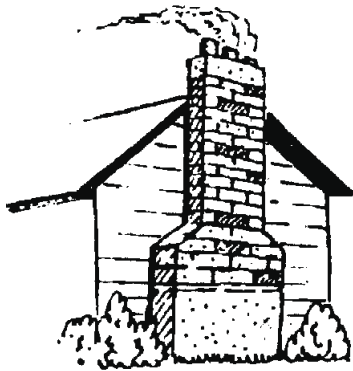

19. Chimney

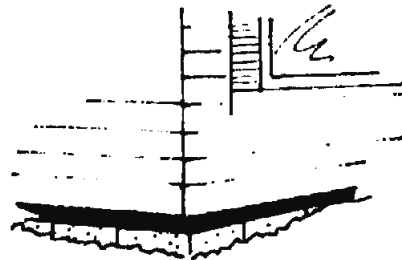

22. House not bolted to foundation

DROP AND COVER



- 1.- Turn away from windows.
- 2.- Crouch under a desk or table.
- 3.- Put both hands on the back of your neck and tuck your head down.
- 4.- If the desk or table moves, hold the legs and move with it.